



NOTES: UNLESS OTHERWISE SPECIFIED.

- 1. MATERIAL: THERMOPLASTIC URETHANE (TPU), SHORE A, COLOR: AS SPECIFIED IN PO. PROVIDE MATERIAL CERTIFICATION WITH EACH SHIPMENT OF PARTS.
- 2.  TEXTURE A-SIDE: STANDARD TEXTURE = SPI FINISH D2.
- 3.  TEXTURE B-SIDE: AS MACHINED
- 4. 3D CAD GEOMETRY DEFINES FEATURES NOT DIMENSIONED. ALL DIMENSIONS IN MM. TOLERANCES: 1 TO 20MM ±.1, 21 TO 100 ±.15, 101 TO 160 ±.325, FOR EACH 20MM OVER 160 ADD ±.08
- 5. CORNER RADII 0.13MM NOMINAL
- 6. TYPICAL DRAFT ANGLE TO BE 1 DEGREE MAX. SEE CAD MODEL FOR ANGLE DETAILS.
- 7. PARTS TO BE CLEAN AND FREE FROM MOLD RELEASE OR ANY CONTAMINATION.
- 8. OVAL DIMENSIONS AND NOTES INDICATE INSPECTION DIMENSIONS.

REVISIONS			
REV	ECO NO.	DESCRIPTION	DRAWN DATE
V1	N/A	PRODUCTION RELEASE	5/5/2016

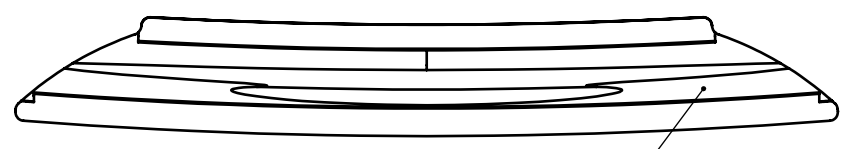
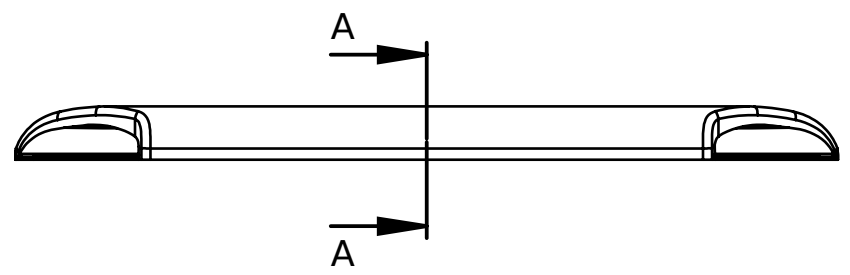
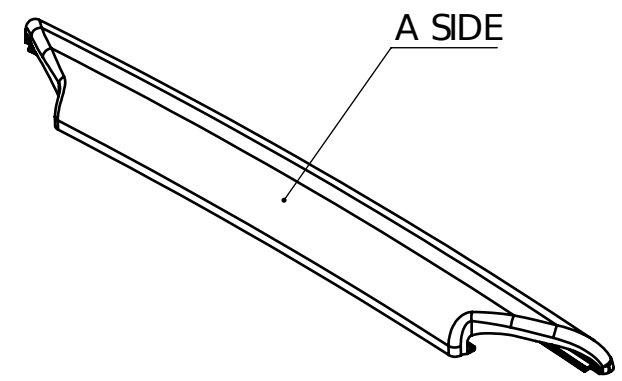
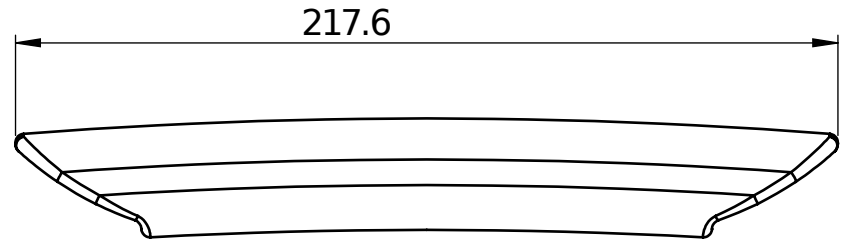
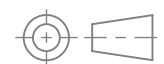

UNLESS OTHERWISE SPECIFIED DIMENSIONS ARE IN MM. TOLERANCES AS FOLLOWS: LINEAR: mm ±.2 ANGULAR: X° ±1°	3RD ANGLE PROJECTION 		CUTTING EDGE PRODUCTS 120 Newport Center Drive Newport Beach, CA 92660 United States www.cepglobal.com 1-800-483-8020		
	MATERIAL	SEE NOTES	TITLE HOUSING A HANDLE		
INTERPRET DIMENSIONS & TOLERANCES PER ASME Y14.5-2009.	FINISH	SEE NOTES			
PROPRIETARY AND CONFIDENTIAL THE INFORMATION CONTAINED IN THIS DRAWING IS THE SOLE PROPERTY OF CUTTING EDGE PRODUCTS CORPORATION. ANY REPRODUCTION IN PART OR A WHOLE WITHOUT THE WRITTEN PERMISSION OF CUTTING EDGE PRODUCTS CORPORATION IS PROHIBITED.	PROJECT	CEP			
	ORIGINATOR	NAME	DATE	SIZE B	DWG NO. C 00023
	DESIGNED BY	B. SPERKO	11/1/2015	SCALE 1:2	SW FILE NAME: C00023 Housing A Handle V1
	DRAWN BY	A. GIFFORD	5/5/20216		
				SHEET 1 OF 1	