





NOTES: UNLESS OTHERWISE SPECIFIED.

- 1. MATERIAL: THERMOPLASTIC URETHANE (TPU), COLOR: AS SPECIFIED IN PO. PROVIDE MATERIAL CERTIFICATION WITH EACH SHIPMENT OF PARTS.
- 2.  TEXTURE A-SIDE: STANDARD TEXTURE = SPI FINISH D2.
- 3.  TEXTURE B-SIDE: AS MACHINED
- 4. 3D CAD GEOMETRY DEFINES FEATURES NOT DIMENSIONED. ALL DIMENSIONS IN MM. TOLERANCES: 1 TO 20MM ±.1, 21 TO 100 ±.15, 101 TO 160 ±.325, FOR EACH 20MM OVER 160 ADD ±.08
- 5. CORNER RADII 0.13MM NOMINAL
- 6. TYPICAL DRAFT ANGLE TO BE 1 DEGREE MAX. SEE CAD MODEL FOR ANGLE DETAILS.
- 7. PARTS TO BE CLEAN AND FREE FROM MOLD RELEASE OR ANY CONTAMINATION.
- 8. OVAL DIMENSIONS AND NOTES INDICATE INSPECTION DIMENSIONS.

REVISIONS			
REV	ECO NO.	DESCRIPTION	DRAWN DATE
V1	N/A	PRODUCTION RELEASE	5/5/2016

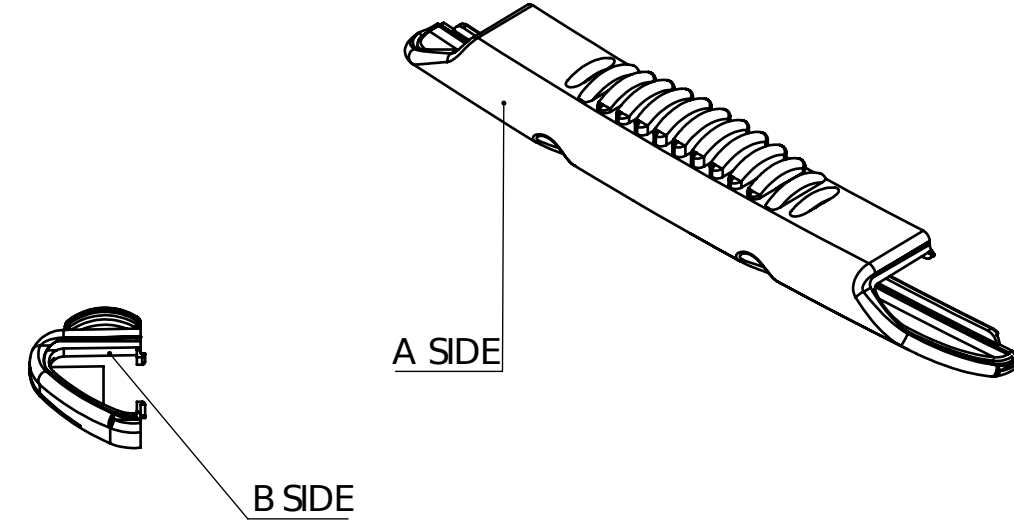
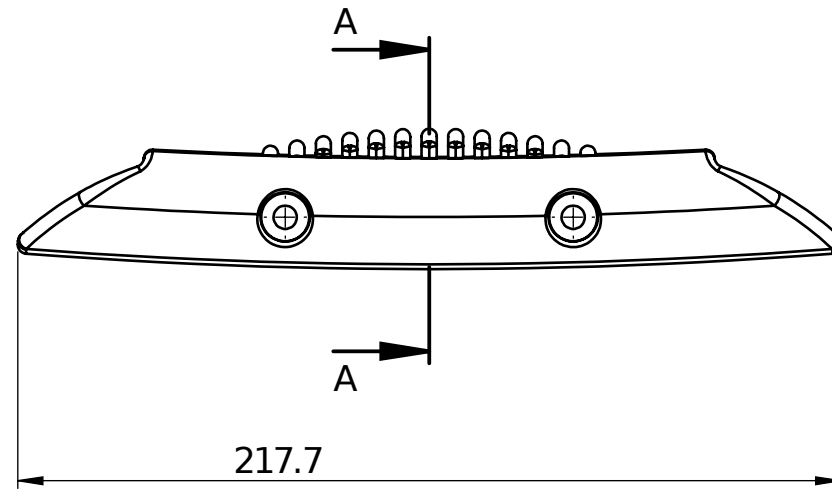
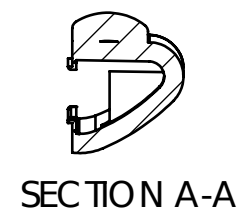

UNLESS OTHERWISE SPECIFIED DIMENSIONS ARE IN MM. TOLERANCES AS FOLLOWS: LINEAR: mm±.2 ANGULAR: X°±1°	3RD ANGLE PROJECTION 		CUTTING EDGE PRODUCTS 120 Newport Center Drive Newport Beach, CA 92660 United States www.cepglobal.com 1-800-483-8020			
	MATERIAL	SEE NOTES	TITLE HOUSING B HANDLE			
FINISH	SEE NOTES					
INTERPRET DIMENSIONS & TOLERANCES PER ASME Y14.5-2009.	PROJECT	CEP	SIZE	DWG NO.		
PROPRIETARY AND CONFIDENTIAL THE INFORMATION CONTAINED IN THIS DRAWING IS THE SOLE PROPERTY OF CUTTING EDGE PRODUCTS CORPORATION. ANY REPRODUCTION IN PART OR A WHOLE WITHOUT THE WRITTEN PERMISSION OF CUTTING EDGE PRODUCTS CORPORATION IS PROHIBITED.	ORIGINATOR	NAME	DATE	B	C 00024	REV V1
	DESIGNED BY	B. SPERKO	11/1/2015			
	DRAWN BY	A. GIFFORD	5/4/20216	SCALE 1:2	SW FILE NAME: C00024 Housing B Handle V1	SHEET 1 OF 1